

TECTUS 340 3D : BLOCK FRAME

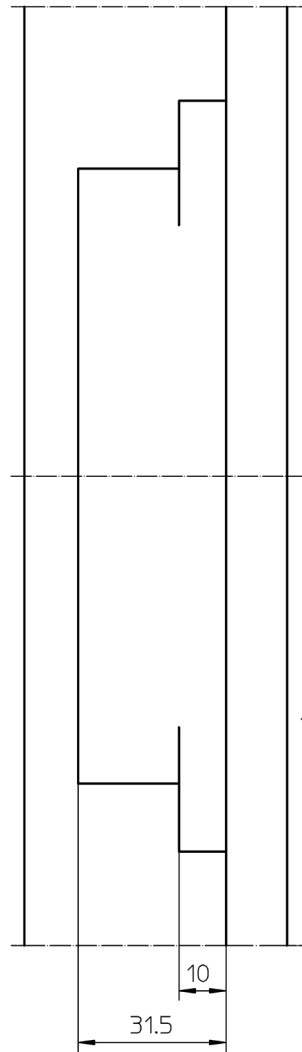

MILLING : FRAME

A = Depth of frame rebate up to sealing
 B = Thickness of door leaf resp. 1st door rebate
 $A - B + 4 = \text{Measure X}$
 The result has to be a measure between 4,0 mm and max. 7,0 mm. (Steel frame: X = 5 mm)

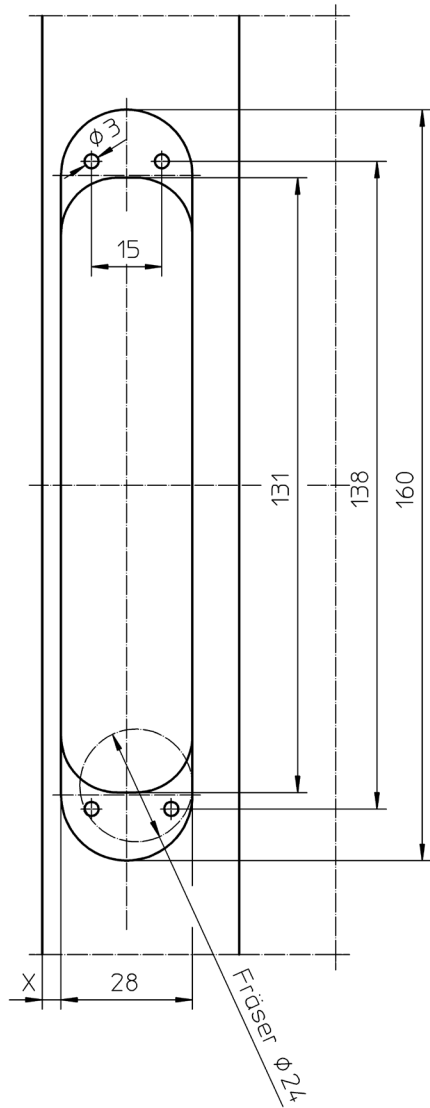
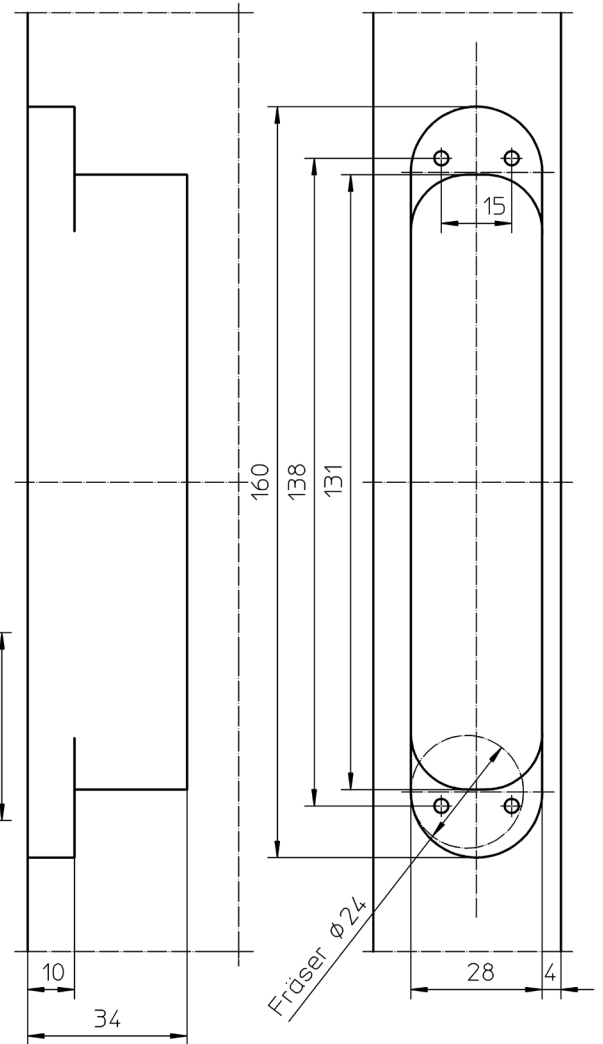
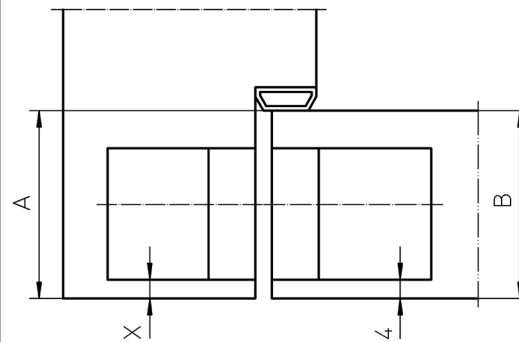

MILLING : DOOR LEAF